

ISA-WELD® - SMD Präzisionswiderstände / SMD precision resistors

TECHNISCHE DATEN / TECHNICAL DATA		
Widerstandswerte (mOhm)	Resistance values (mOhm)	0,2, 0,3, 0,5, 0,6, 1, 2 mOhm
Toleranz	Tolerance	1 %, 5 %
Temperaturkoeffizient*	Temperature coefficient (tcr)*	ab 50 ppm/K (20 °C - 60 °C)*
Temperaturbereich	Applicable temperature range	-55 °C bis/to +170 °C
Belastbarkeit	Load capacity	bis/up to 10 W *
Innerer Wärmewiderstand (R_{thi})	Internal heat resistance (R_{thi})	ab/from 4 K/W *
Induktivität	Inductance	< 3 nH
Stabilität (Nennlast) Abweichung T_K = Kontaktstellentemperatur Stability (nominal load) deviation T_K = Terminal temperature		< 0,5 % nach/after 2000 h (T_K = 100 °C) < 1,0 % nach/after 2000 h (T_K = 130 °C)

* siehe Tabelle Seite 3 / see table on page 3

MERKMALE / FEATURES

- 10 Watt Dauerleistung*
10 Watt permanent power*
- Dauerströme bis 220 A (0,2 mOhm)
Continuous current load up to 220 A (0.2 mOhm)
- Massive Kupferanschlüsse
Heavy copper connectors
- Sehr gute Langzeitstabilität
Excellent long term stability
- Ideal geeignet für die Montage auf DCB Keramik /
IMS Substrat
Ideally suited for mounting on DCB / IMS substrate
- Geeignet für Löttemperaturen bis 350 °C / 30 sek
Max. solder temperature up to 350 °C / 30 sec
- AEC-Q200 qualifiziert
AEC-Q200 qualification

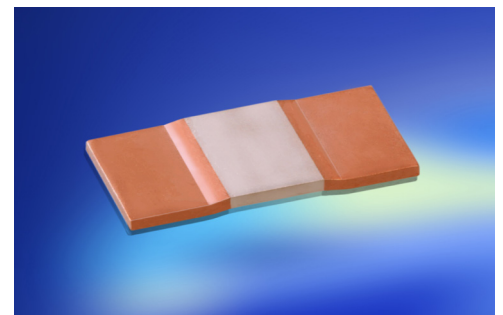

Bauform/Size 5930

APPLIKATIONEN / APPLICATION

- Messwiderstand für Leistungshybride
Current sensor for power hybrid applications
- Für Schweißmontage an Stromschienen
For welding on bus bars
- Hochstromanwendungen in der Automobiltechnik
High current applications for the automotive market
- Frequenzumrichter
Frequency converters
- Leistungsmodulare
Power modules

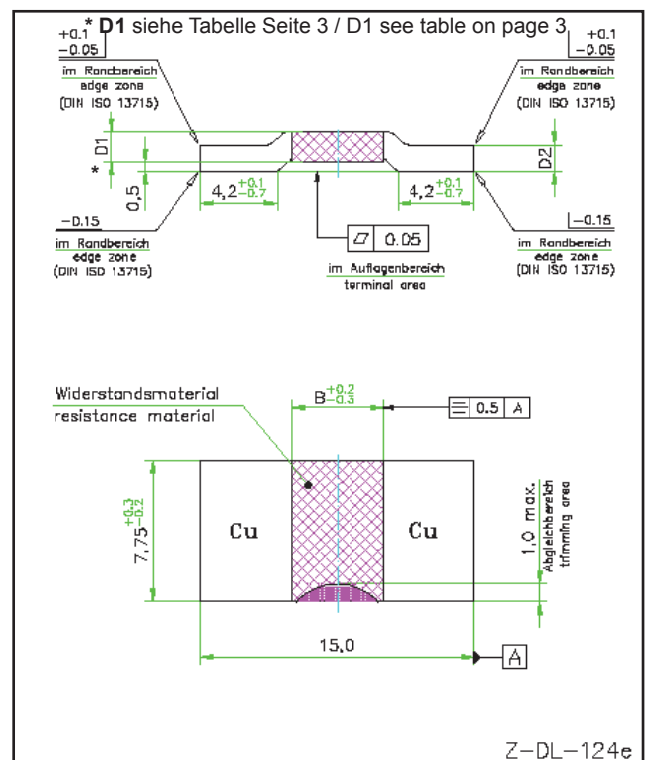

TK, Lastminderung und Langzeitstabilität / TCR, power derating and long term stability

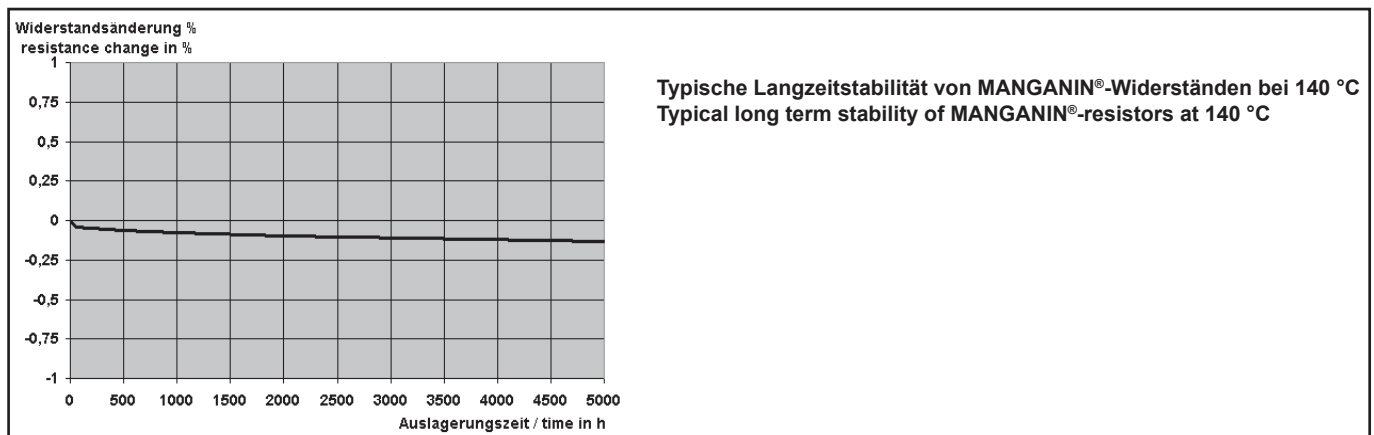
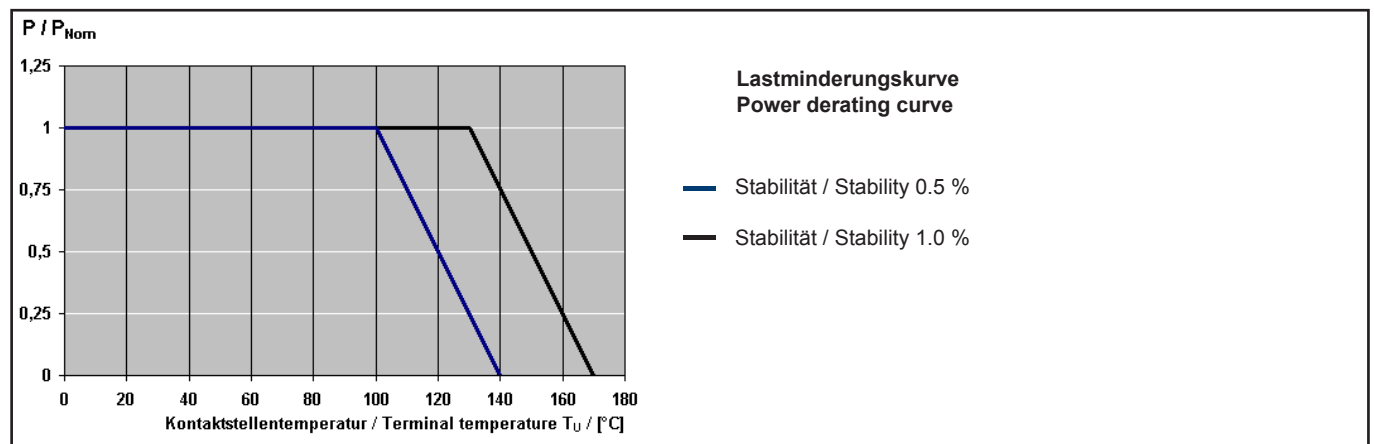
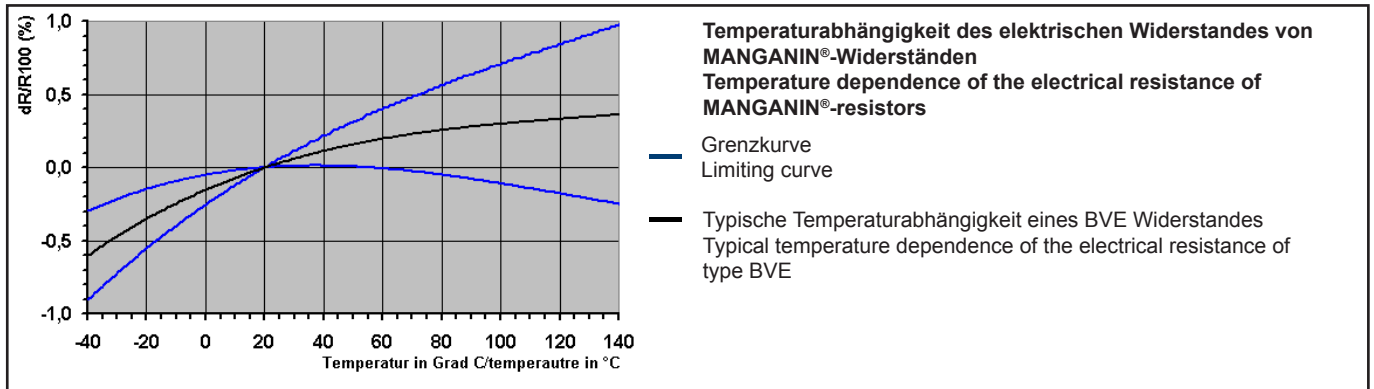

Vorschlag für Leiterplatten Layout (Reflowlöten) Proposal for pcb-layout (Reflow soldering)

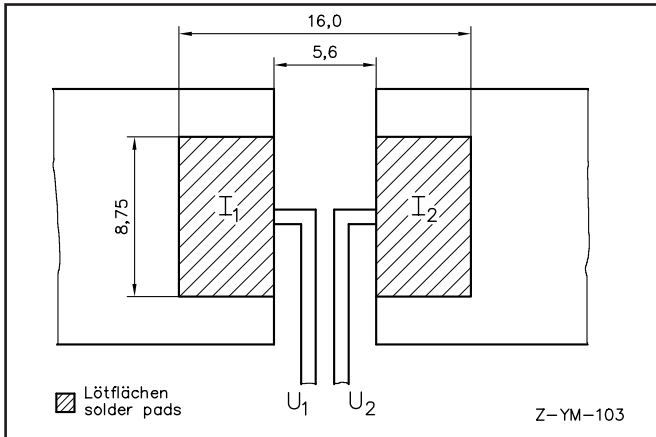

Lötprofil Vorschlag / Recommended solder profile			
Reflow-, IR-löten / Reflow-, infrared-soldering			
Temperature	260 °C	255 °C	217 °C
Zeit / time (s)	Peak	40	90
RoHS 2002/95/EG konform seit Produktstart. Ausführliche Informationen erhalten Sie auf unserer Homepage: www.isabellenhuette.de RoHS 2002/95/EC compliance since product launch. For more information please visit our website: www.isabellenhuette.de			

GURTINFORMATIONEN / TAPE & REEL INFORMATION	
Norm / Specification	DIN EN 60286-3
Gurtbreite / Tape width	24 mm
Anzahl Bauteile / Parts per reel	2000 Stk. / pcs.

BESTELLBEZEICHNUNG / ORDERING CODE			
BVE-M-R0005-1.0			
Typ	Material	Widerstandswert	Toleranz
Type	Material	Resistance value	Tolerance
BVE	MANGANIN®	0.5 mOhm	1.0 %

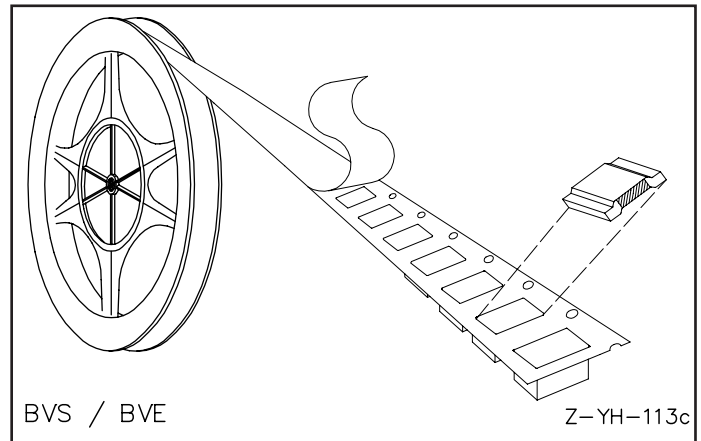

Typ	Wert / mΩ	Dicke (D1) / mm	R _{thi} / K/W	TK / ppm/K	P / W
Type	Value / mΩ	Thickness (D1) / mm	R _{thi} / K/W	TC / ppm/K	P / W
BVE-M-R0002	0.2	1.42	3	100	10
BVE-M-R0003	0.3	0.94	4.5	100	7
BVE-M-R0005	0.5	0.56	8	75	6
BVE-M-R0006	0.6	0.48	10	75	5
BVE-A-R0005	0.5	1.63	5	75	7
BVE-A-R001	1	0.91	8	50	6
BVE-I-R002	2	0.44	16	50	4

Abkürzung Typ / Abbreviation type A=Aluchrom, M=MANGANIN®, I=ISAOHM®

Gewährleistung

Alle Angaben über Eignung, Verarbeitung und Anwendung unserer Produkte, technische Beratung und sonstige Angaben erfolgen nach bestem Wissen, befreien den Käufer jedoch nicht von eigenen Prüfungen und Versuchen.

Warranty

All information regarding the suitability, workability and applicability of our products, all technical advice and other information are provided to the best of our knowledge and belief, but shall not discharge the buyer from his own examinations and tests.

Grenzkurve für maximale Pulsenergie bzw. Pulsleistung für Dauerbetrieb Maximum pulse energy respectively pulse power for continuous operation

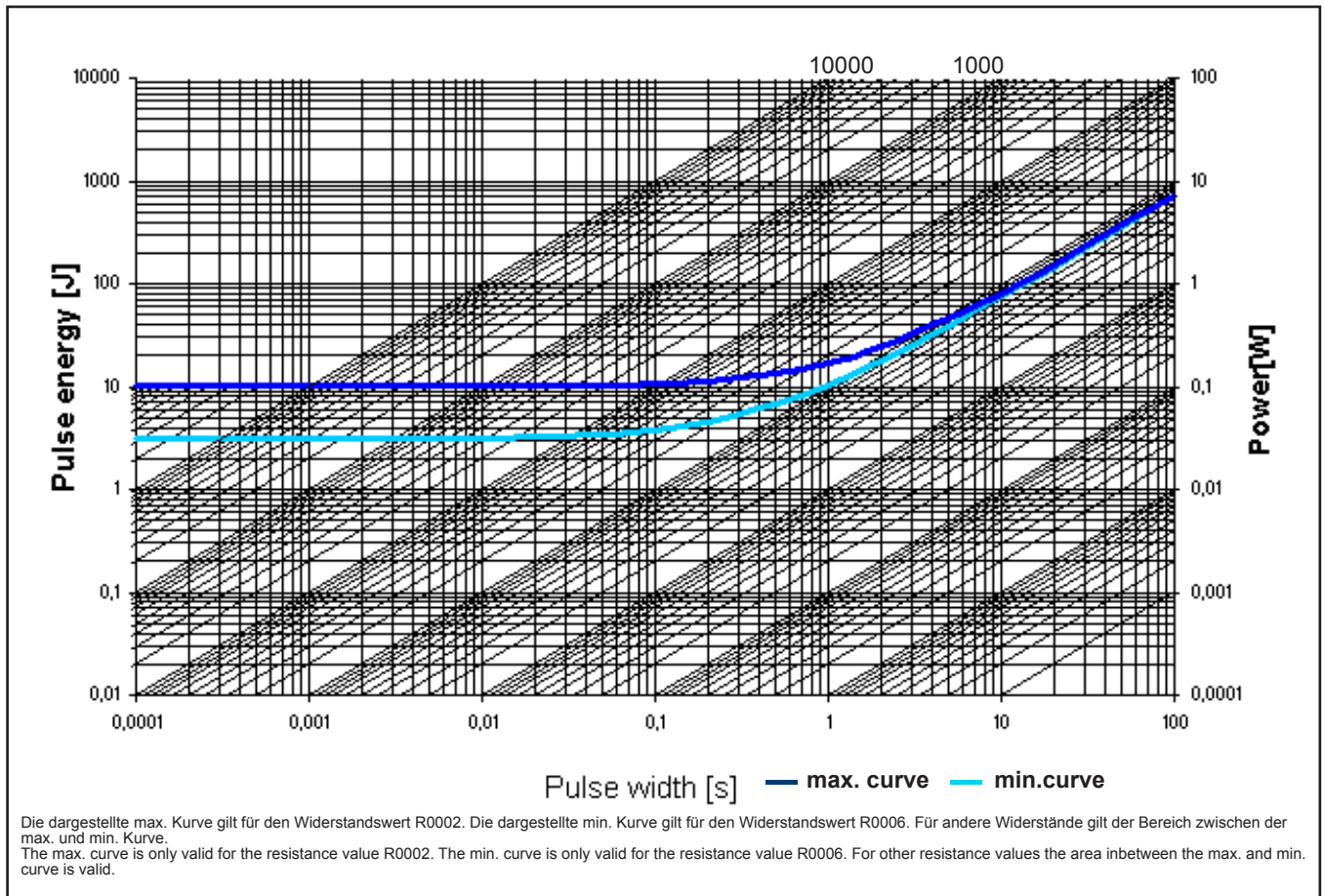

Spezifikation / Specification			
Parameters	Test Conditions	Specification	Typical data
Maximum Temperature for full power operation	100 °C	100 °C	100 °C
Working Temperature	-55 to 170 °C	-55 to 170 °C	-55 to 170 °C
Thermal Shock	MIL-STD-202 method 107-B1	0.1 %	0.05 %
Overload	MIL-R-26E (5 times rated power, 5 sec)	0.2 %	0.1 %
Solderability	MIL-STD-202 method 208	> 95 % coverage	> 95 % coverage
Resistance to Solvents	MIL-STD-202 method 215, 2.1a, 2.1d	no damage	no damage
Low Temperature Storage and Operation	MIL-STD-26E	0.1 %	0.03 %
Resistance to Soldering Heat	MIL-STD-202 method 210	0.1 %	0.02 %
Moisture Resistance	MIL-STD-202 method 106	0.1 %	0.01 %
Shock	MIL-STD-202 method 213-A	0.2 %	0.1 %
Vibration, High Frequency	MIL-STD-202 method 204-B	0.2 %	0.05 %
Life	MIL-STD-26E	0.2 %	0.1 %
Storage Life at Elevated Temperature	MIL-STD-202 method 108-F	0.3 %	0.2 %
High Temperature Exposure	100 °C, 2000 h	0.2 %	0.1 %
Current Noise	MIL-STD-202 method 308	0.01 %	0.001 %
Voltage Coefficient (%/V)	MIL-STD-202 method 309	linearity error less than 120dB	
Resistance Temperature Characteristic AluChrom/Maganin®	MIL-STD-202 method 304 (20-60 °C)	< 50 ppm/K / 100 ppm/K	< 50 ppm/K / 100 ppm/K
Thermal EMF	0 - 100 °C	2 µV/ K max.	1 µV/ K
Frequency Characteristic	inductivity	< 3 nH	< 3 nH